

Secure, safe, authorized & certifiable edge & cloud key components

Focus: Demonstrate a safe compute platform and middleware for cloud-distributed safety-critical applications, on multiple distributed replicas

What are we working on?

Safe compute platform for safety-critical embedded systems, e.g., railway, automotive, industrial control, and other domains. The safe compute platform features a hypervisor controlled by a Kubernetes interface.

Reference implementation for the OCORA PI, a middleware for cloud-distributed safety-critical applications on multiple distributed replicas for safety. We abstract replicated communication away from application development.

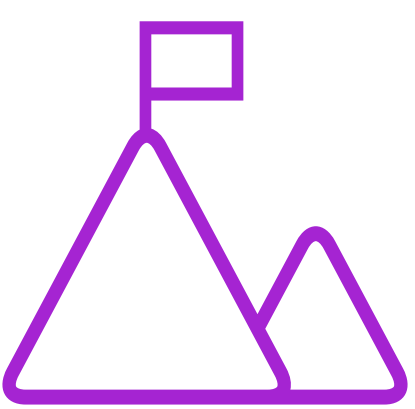
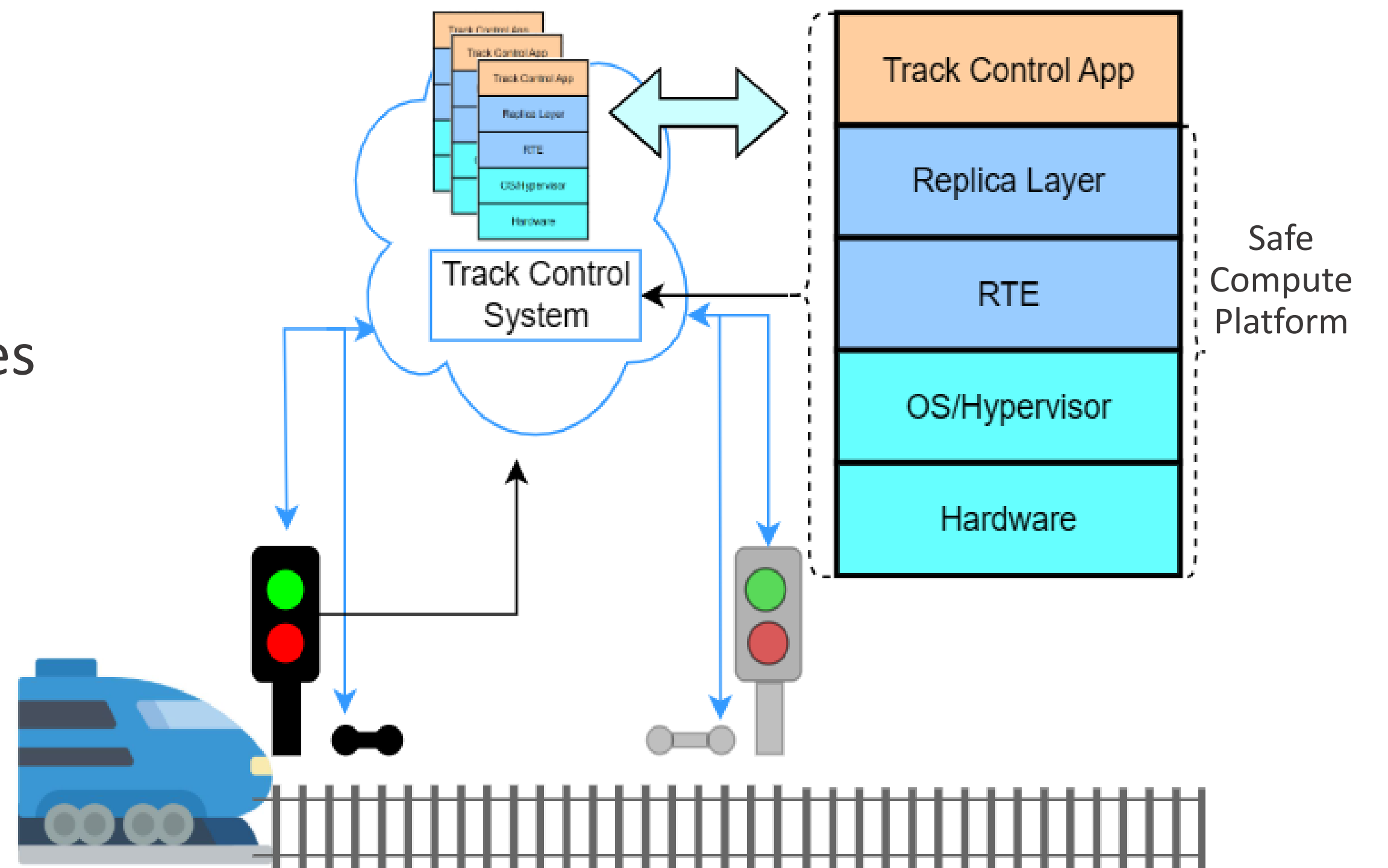

What have we achieved?

- Specification of OCORA PI API for flow management and voting
- Use of DDS (data distribution service) based OCORA PI flow and voting implementation, and Kubernetes control of hypervisor in lab

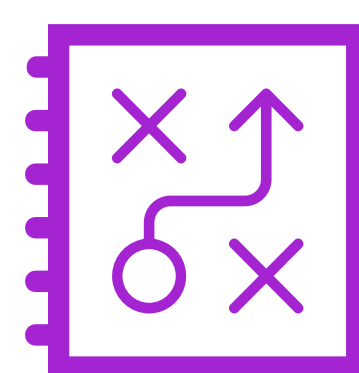
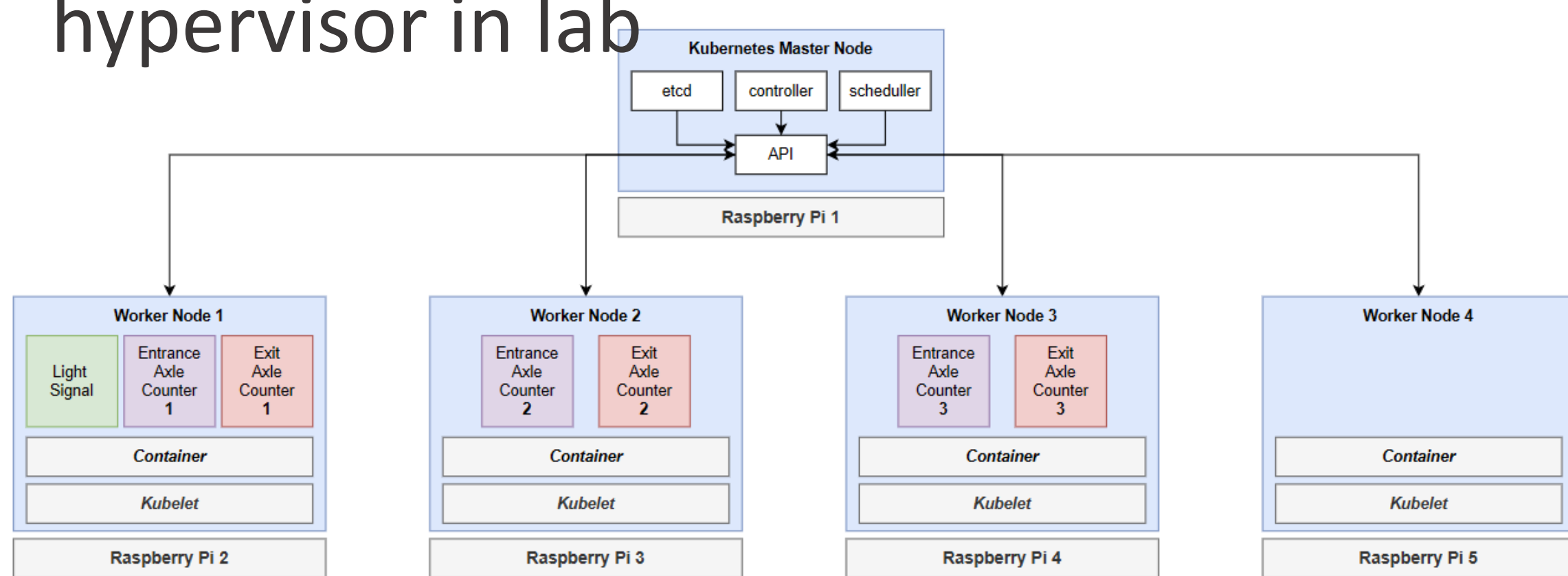

Current Challenges

- Hardware selection of field demonstrator
- Identifying and implementing relevant subset of Kubernetes API control interface for the hypervisor
- Optimal error handling in distributed systems

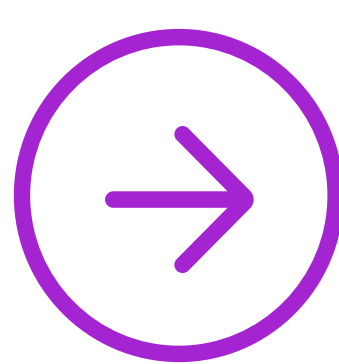
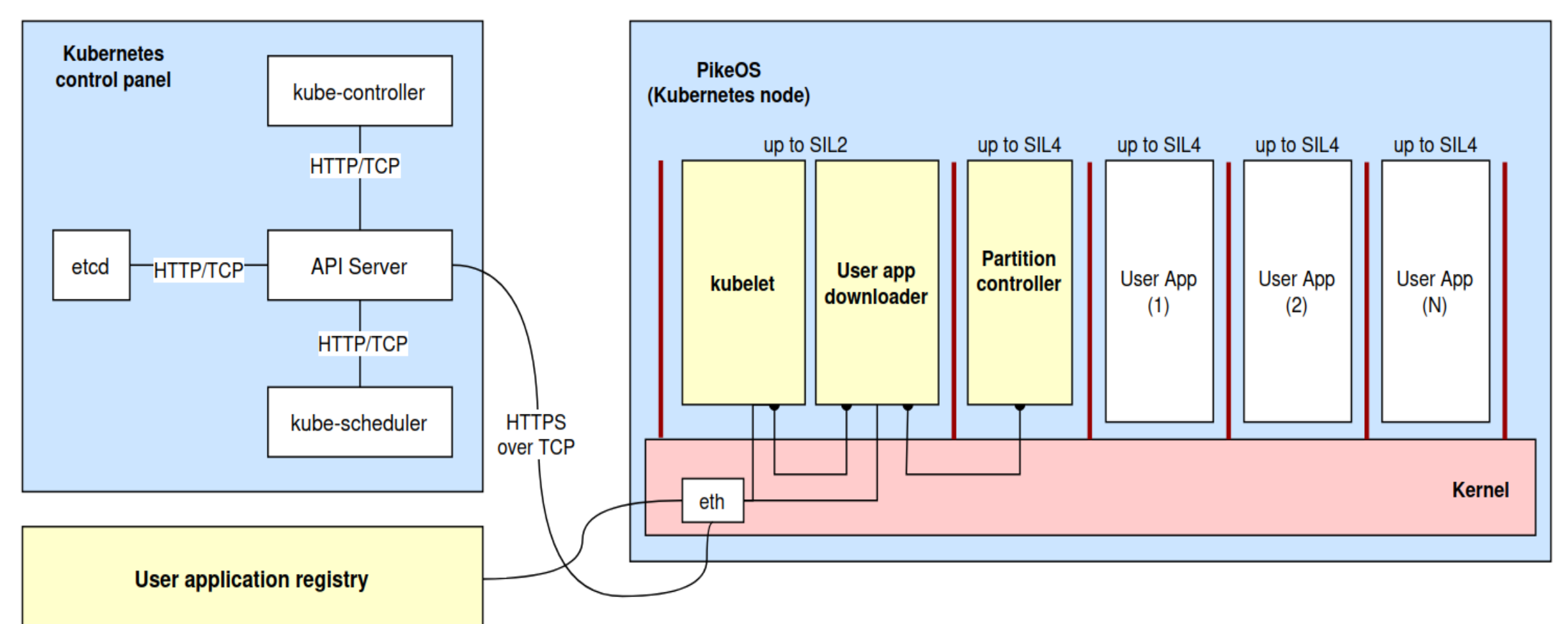

Next Steps

- Increasing maturity by field demonstration in Q4 2026
- Integration into edge-cloud platform for safety-critical systems

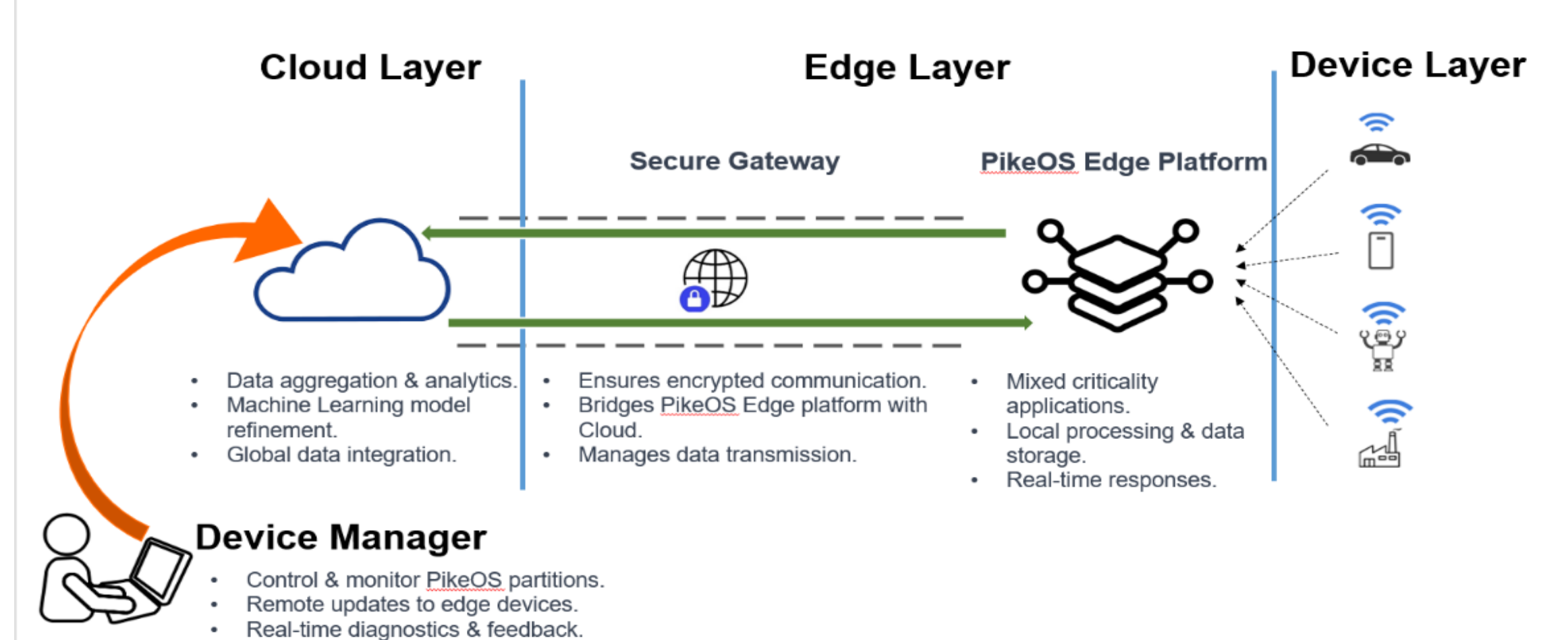

Contact

George Violettas
george.violettas@sysgo.com

Mario Brotz
mario.brotz@sysgo.com



Let's connect on...

- Modular platforms for safety, Kubernetes on embedded systems
- Safe Compute Platform
- Safe Cloud Platform

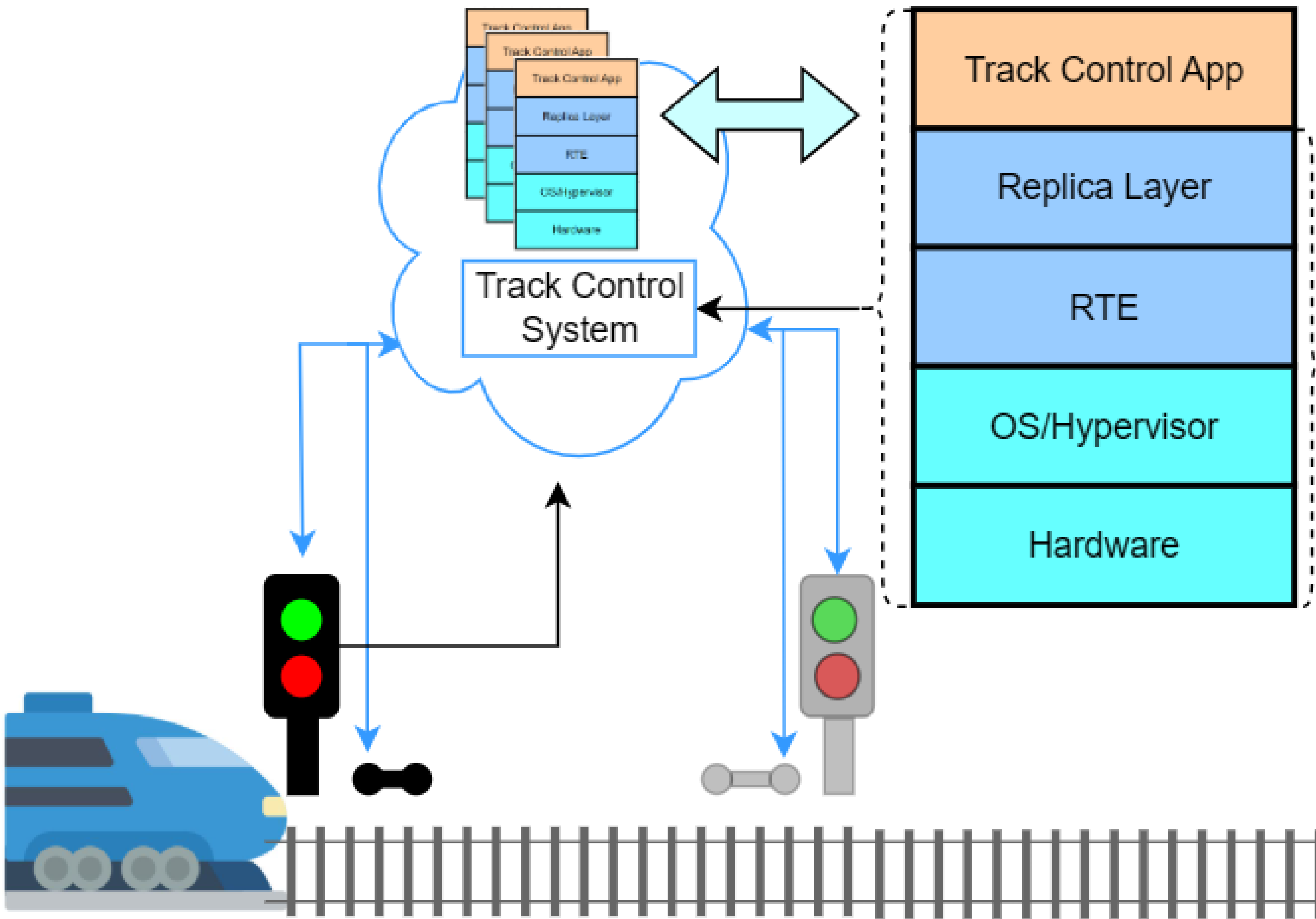

PikeOs Edge Computing Platform

